



HVLS FAN

High Volume Low Speed Fan



Industrial Cooler



Exhaust Fan

The Marut Air

Marut Air is an India based ventilation company, established with the purpose of cheapest ventilation in big premises and to cut the carbon footprint by reducing the electricity consumption.

Insignificant rise in temperature has created a significant need of cooling and ventilation solutions in large premises. When we think of conventional solutions on it, they are insufficient, less productive and high energy consumption.

Most of the industrial sheds are designed with turbo ventilators and high-speed fans on floor, but to combat temperature inside the building; some creative and cost-effective solution is needed.

Marut Air has come up with complete package of modern & creative solutions addressing the issue with highly engineered processes.

"We can't solve problems by using the same kind of thinking we used when we created them."

- Albert Einstein

Our Solution:



1. Create fresh air by industrial air coolers

2. Hot Air Elimination by Exhaust fans.

3. Circulate air by High Volume Low Speed Fan

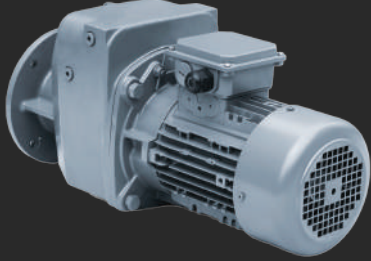

Advantages Of Marut PMSM (HVLS) Fans

 <p>Conventional HVLS (Gearbox)</p>	 <p>Marut HVLS (PMSM)</p>
Gear Reducer Type Motor	Direct Drive Servo Motor
Power consumption is too high	Less energy loss, Optimal performance, Highest power saving!
Less electricity savings	Modern engineering, Saves huge cost
Periodic Maintenance required for oil seal, gearbox oil	Simple design, No Maintenance
Made with Gear Reducer Type.	Made with rare earth Neodymium magnets (20X better life)

Installation Requirements

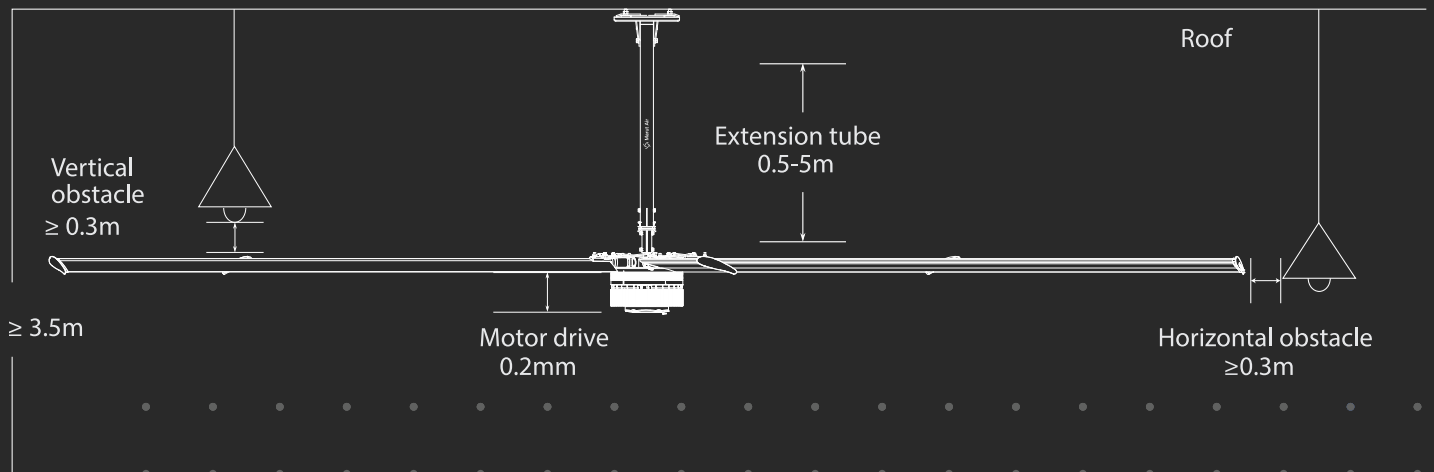

Function Introduction

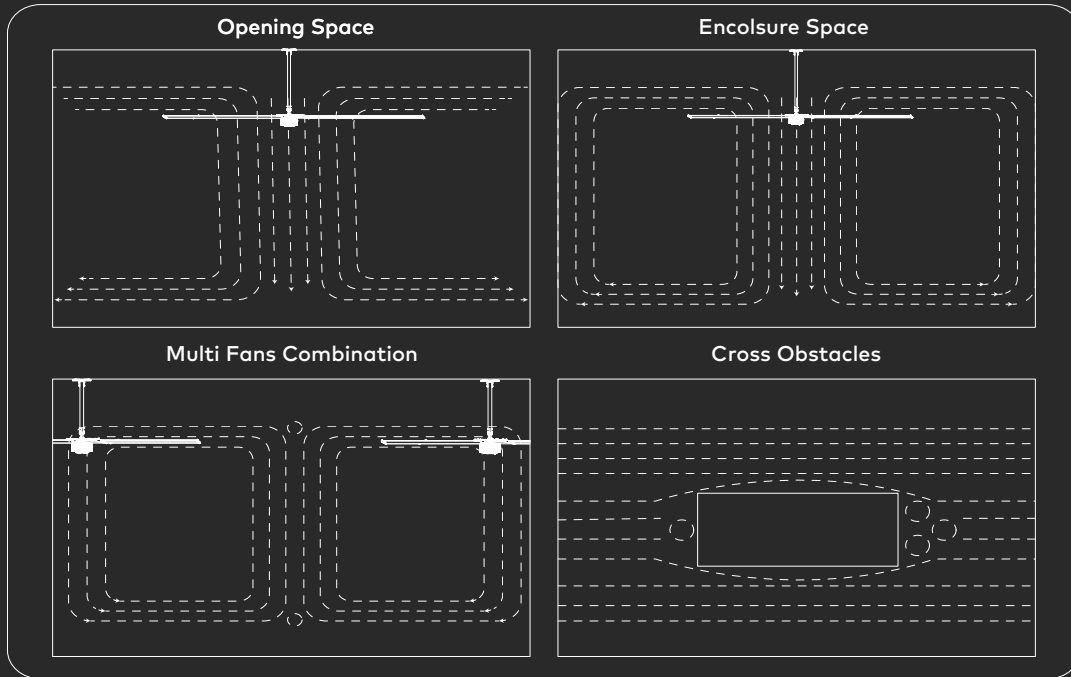

One-of-a-kind Features of Generation-3 Marut Fans

- **Dual Cooling System:** Air + Liquid cooling mechanisms to ensure longer lifespan.
- **Longer Lifespan:** Motors equipped with high-temperature resistive magnets & windings.
- **Maximum Temperature Threshold:** The temperature sensors are set to stop the fan at 130° C.
- **Thick Blades:** Significant thick blades compared to standard designs.
- **Fall Prevention Design:** Specifically designed to prevent falls or accidental drops.



Marut HVLS PMSM Fan Technical Configuration

Model	Size (Dia)	Motor kW/HP	RPM	Air Volume (CMM)	Total Weight (Kg)	Coverage (SQ.M)	Frequency (Hz)	dBA*
MRT-7a-G3	7.3m(24ft)	1.1/1.5	0-55	13,000	116	1500	50/60	38
MRT-6a-G3	6.1m(20ft)	1.1/1.5	0-60	11,500	113	1000	50/60	38
MRT-5a-G3	5.5m(18ft)	1.1/1.5	0-70	11,000	111	900	50/60	38
MRT-4a-G3	4.9m(16ft)	0.75/1.0	0-70	10,000	69	600	50/60	38
MRT-3.7a-G3	3.7m(12ft)	0.37/0.5	0-100	5,000	56	380	50/60	38
MRT-3a-G3	3.0m(10ft)	0.37/0.5	0-115	4,000	50	250	50/60	38

*dBA - Fans sound are tested in lab condition actual result may vary due to environment condition and surface reflection.
 Warranty - 1 year whole fan system warranty, Other specifications and models can be customized according to customer needs



Industrial Cooler



Model	MR-25
Airflow (m3/h)	25,000
Power(kW)	1.5
Fan Type	Axial
Water Tank(L)	36
Noise(dB(A))	≤70
Control System	Frequency inverter system
Air Outlet Size (mm)	670*670
Net Weight(kg)	82
Coverage(m2)	100-200
Dimension(mm)	1140*1140*1350
Water Consumption (L/H)	65-90 L/h
Frequency Inverter	50Hz
Honeycomb pad size (mm)	(910+30+30)*775*100
Electrical Protection	Current & Amp Protection, Phase Detection



IIMA RESERCH

Worker productivity can be enhanced by up to 12% by increasing the level of cooling comfort at workplace, according to a study by Indian Institute of Management-Ahmedabad

Benefits of Air Cooler

- Improve working environment By Increasing cool and fresh air Intake.
- Increases productivity of the employees.
- Low energy consumption with high result.
- Most cost effective solution for Medium to Big premises.
- Low Maintenance and payback in just six months.

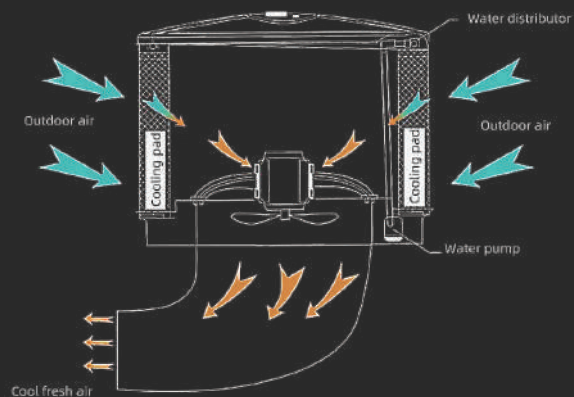

Industrial Louvers

Model	Dimension (mm)	Frame Material	Operation
ML-1380	1380 X 1380 X 250	0.8mm Galvanized	Manual/Electric Push Rod

Advantages of Automatic Industrial Louvers

- New age solution for Ventilation
- Increases Air changes per hour by natural ventilation
- Runs without electricity
- Simple Construction-longer service life
- Water leakage proof
- On/ Off Function



Exhaust Fans

Model	Diameter blades (mm)	Noise (decibels)	Air flow (m ³ /h)	Blades rotational speed (r/min)	Import power (W)	Pressure (Pa)	Rated Voltage (V)	H X W X Thickness (mm x mm x mm)
MCG-1000	900	≤70	30,000	620	750	70	415	1000x1000x400
MCG-1380	1250	≤70	44,000	439	1100	56	415	1380x1380x400



Working Principal of an Exhaust Fan

Exhaust Fan draws out polluted air from premises and replaces it with fresh air. Air is considered polluted when it contains high amounts of Hot air, moisture, carbon dioxide, vaporized chemicals, dust, fungal spores and unpleasant odors. Marut Air exhaust fan combat indoor air pollution by ejecting the unclean indoor air into the outside environment and letting in clean air from the outside.



*Exhaust fans in non-working condition: louvers closed



*Exhaust fans in working condition: louvers opened



Mobile Fans

Model	Diameter (mm)	Voltage (V)	Frequency (Hz)	Power (w)	Rotating Speed (rpm)	Air Speed (m/s)	Air Flow (m ³ /min)	Weight (kg)	Noise (db)	Coverage Area (m ²)
MRT-2M	2,000	220/380	50/60	550	≤240	1-5	1,000	121	39	260
MRT-1.5M	1,500	220/380	50/60	370	≤400	1-5	700	80	39	150

Installation Conditions

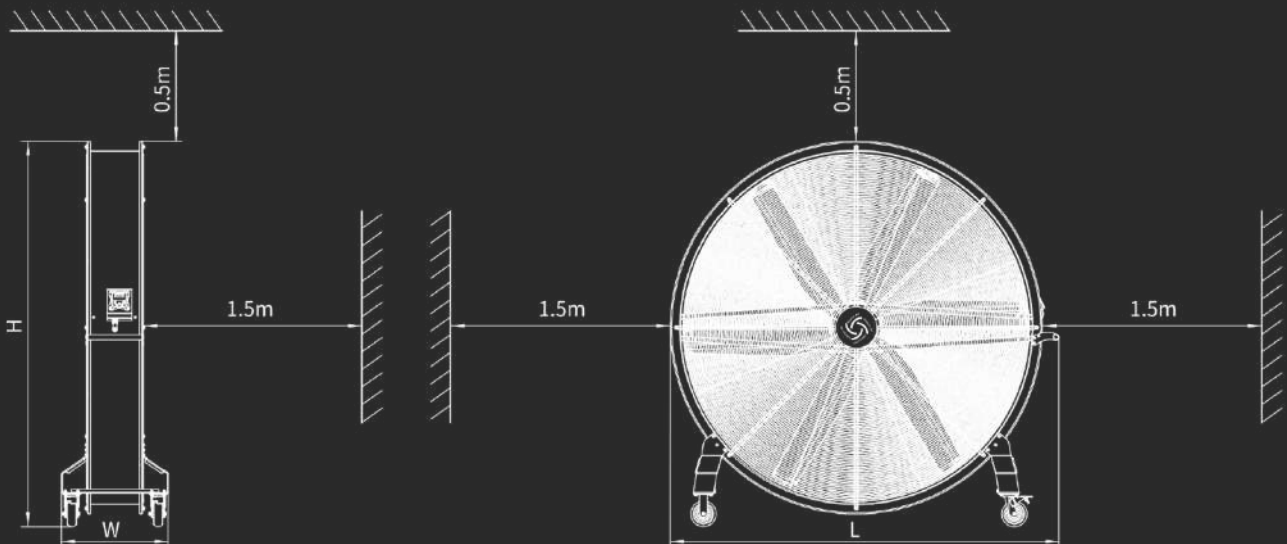

Marut Air Hanging Fans

Model	Dimension (mm)	Voltage (V)	Power (Kw)	Air Flow (m ³ /h)	Blade Diameter (mm)	No of Blades	Frame Material	Blade Material
MH - 1100	1100 x 1100 x 350	415	0.55	32,500	1,000	4	Galvanized sheet/ Plastic	430 Stainless steel

Advantages of Hanging Fans

- Large Airflow
- Easy Installation, Can be hanged from roof or side walls
- Simple Construction – Easy to use
- Ideal for targeting specific area
- Suitable to cover low height area

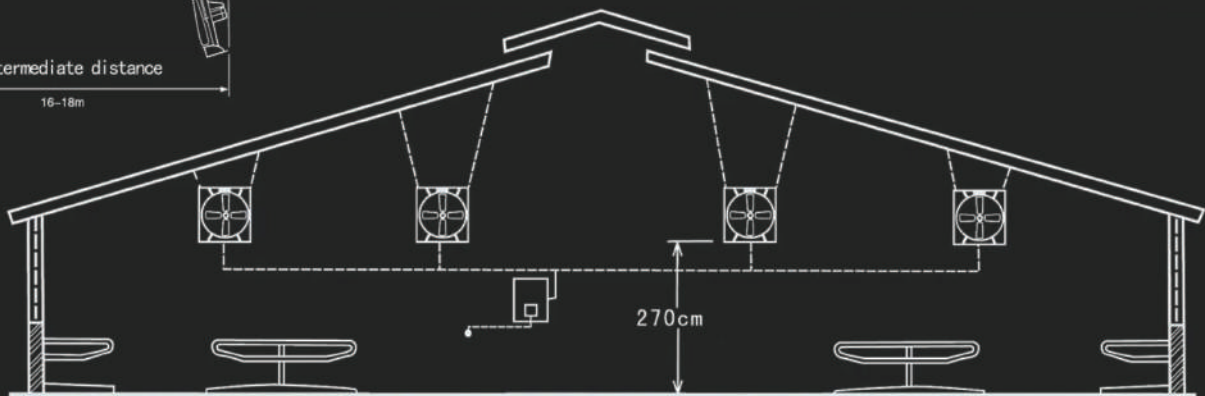
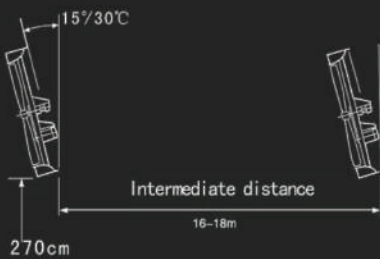
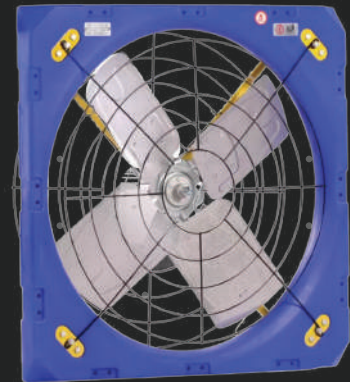
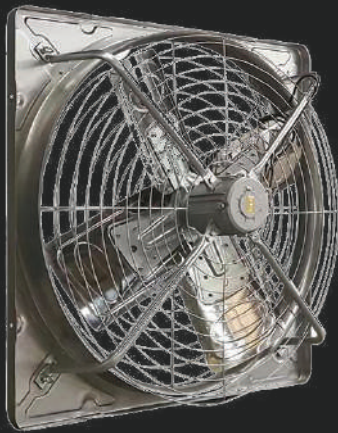

Commercial Fans



Model	Diameter (m)	Air Volume (m ³ /min)	Speed (rpm)	Noise (dB)	Power (Kw)	Fan Weight (kg)	Coverage Area (m ²)
MRT-1d	1.8	2000	160	≤38	0.3	38	120
MRT-2d	2.4	2600	160	≤38	0.3	36	140
MRT-3d	3	3300	105	≤38	0.3	38	210

Applications

Efficient Air Circulation & Attractive Design makes MARUT Commercial Fans outstanding!



GYM



Hotel Reception



House



Indoor Sports



Restaurants & Cafe



Workshop

Distinctive Advantages



Attractive design.



Significant cost savings on HVAC expenses.



Noiseless operation.



Maintenance-free experience.



Perfect for spaces with a 10-foot ceiling height.

More About Marut Air

5

Star satisfaction consistently

700+

Industry leaders using our product daily

7.2+M

m² premises made ventilation perfect so far

Some of our Happy Clients



adani

safari



NYKAA



YIZUMI



SIEMENS



VOLTAS



P. +91 63511 72403

| E. info@marutair.com

| www.marutair.com

Marut Air Systems Pvt. Ltd.

Marut Corporate House, Behind The Capital, Science City Road, Ahmedabad - 380060

Dealers & Distributors